

# USER MANUAL



Thank you for choosing Better Bathrooms.  
Please read this manual before installing your product  
and keep for future reference.

**better**   
**bathrooms**

## BACK-TO-WALL INTELLIGENT TOILET

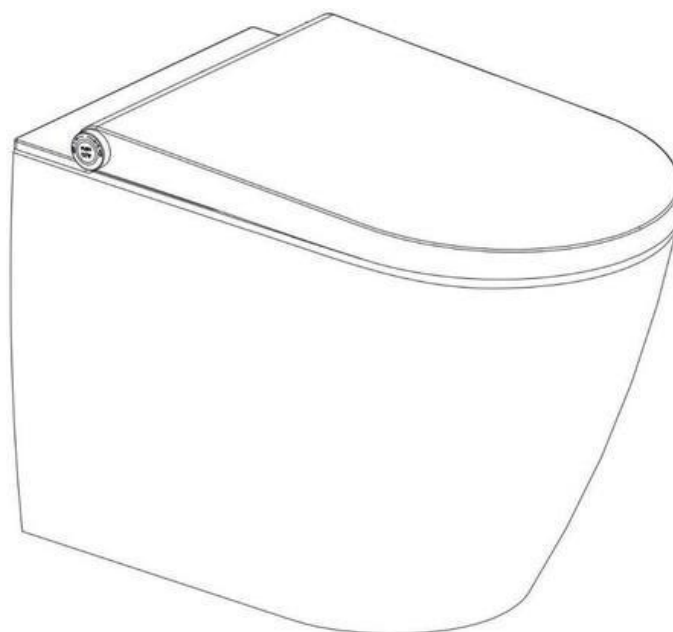

## PURMBBTW

- REMOTE CONTROL
- IPX4 INGRESS PROTECTION
- REAR AND FRONT WASH

V20260122J

# CONTENTS

SAFETY INFORMATION	3
BATHROOM ZONES	4
UNIT MEASUREMENTS	5
PARTS LIST	6
TOOLS REQUIRED	7
PRODUCT OVERVIEW	8
BEFORE INSTALLATION	9
INSTALLATION	10
REMOTE CONTROL	16
OPERATION	17
REPLACING THE FILTER	22
DESCALING THE DEVICE	23
DRAINING THE WATER TANK	24
ONE-ON-ONE SETTING	24
RESTORE FACTORY SETTINGS AND BATTERY REPLACEMENT	25
CLEANING AND MAINTENANCE	26
TROUBLESHOOTING	27
BATTERY WARNINGS	29
TECHNICAL SPECIFICATION	30
SUPPORT	31

## **SAFETY INFORMATION**

- This manual must be read and fully understood before installing or using the appliance.
- This product must not be operated without a connected water supply.
- Installation must be in accordance with all relevant local regulations applicable at the time of installation.
- It must be installed by a qualified professional to in accordance with BS 7671.
- If electrical work is carried out within the bathroom, which involves the addition or alteration of existing circuits, it may be notifiable to your local building control department (Part P). If unsure, professional advice should be sought.
- The toilet must be fitted in accordance with the Water Supply (Water Fittings) Regulations and Water Supply (Water Fittings) (Scotland) Byelaws.
- If the power cable or RCD are damaged in any way, the power must be disconnected until the part is replaced. Contact the retailer or manufacturer.
- The toilet must be fitted in a well-ventilated bathroom.
- The toilet must not be sprayed with liquid or placed in a position it is likely to be sprayed.
- The toilet must not be installed in a location where it may be subject to high temperatures.
- The toilet must be stored in an upright position before installation.
- Do not over bend or kink the water supply hose as this could cause leaks
- Only use this product for its intended use. Only use attachments recommended by the manufacturer.
- Do not use this product in an outdoor environment.
- This appliance can be used by children below 3 years but require constant observation by an adult in the immediate proximity of the child. This appliance can be used by children aged from 3 years and above and persons with reduced physical, sensory or mental capabilities or lack of experience and knowledge if they have been given supervision or instruction concerning use of the appliance in a safe way and understand the hazards involved. Children shall not play with the appliance.
- Children and people with limited physical, sensory or capabilities must be supervised when using this device or have been told the proper procedure for use beforehand.
- Cleaning and user maintenance shall not be made by children without supervision.
- Do not climb or stand on the toilet.
- If the product is not working properly, disconnect from the mains and close the water supply valve immediately before contacting the supplier or a qualified professional.
- This is a Class I electrical appliance and must be correctly earthed. Make sure the earth cable is connected first during the electrical connection.
- In case of any damage to the supply cable, you must arrange for a certified and qualified electrician to replace the cable for you.
- This appliance is designed for fixed connection to the power supply. Connecting this appliance to the power supply must be performed by a qualified and authorised electrician.
- Incorrect repairs are dangerous. Repairs must only be carried out by trained and qualified engineers.
- The Supplier and Manufacturer are not responsible for any injury and/or damage caused by incorrect installation, maintenance or operation of the product.
- Do not force the soft close toilet seat down as this may damage the mechanism.
- A defective appliance may cause electric shock. Never switch on a defective appliance. The power must be disconnected before seeking assistance.
- This product is IPX4 rated, and so no part of the installation is allowed to be within bathroom Zones 0 or 1. Installation is permitted within Zone 2 and outside of the bathroom zones as long as it is not in a position where it is likely to be sprayed with water.

## BATHROOM ZONES

If the appliance is to be fitted within a bathroom, a good understanding of the zoning within bathrooms is required to ensure the unit is mounted in a safe position. The appliance is rated as IPX4 and should be installed outside of Zones 0 -2. We would advise when the unit is fitted within a bathroom, the plug is removed from the unit, and a suitable fused spur is installed in accordance with BS 7671. In addition, when used in a bathroom, it must be protected by a suitable RCD to prevent the risk of electric shock and must not be immersed in water when cleaning.

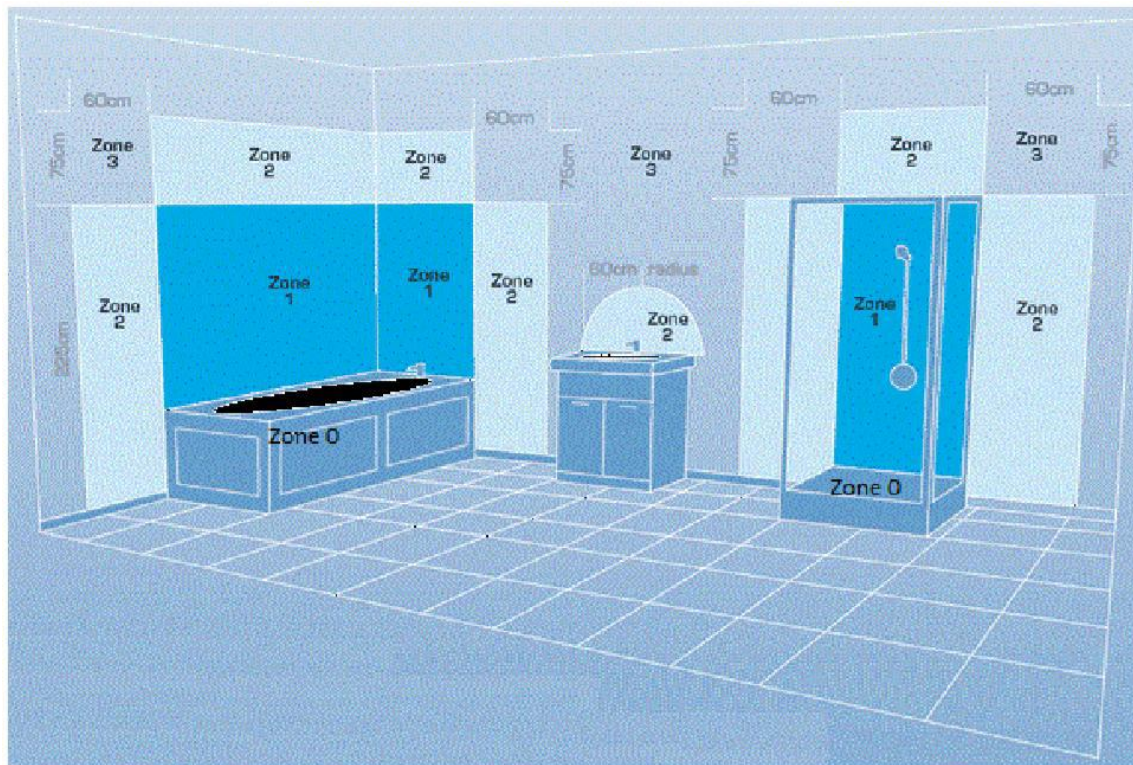

<b>Zone 0:</b>	The interior of the bathtub or shower basin.
<b>Zone 1:</b>	The area around the bathtub or shower basin up to a height of 2.25m above the floor
<b>Zone 2:</b>	The area stretching to 0.6m outside the bath or shower and above the bath or shower if over 2.25m

## DIMENSIONS

**NOTE:** Images are for illustrative purposes only, as the product is subject to continual improvement. All dimensions are in millimetres (mm).

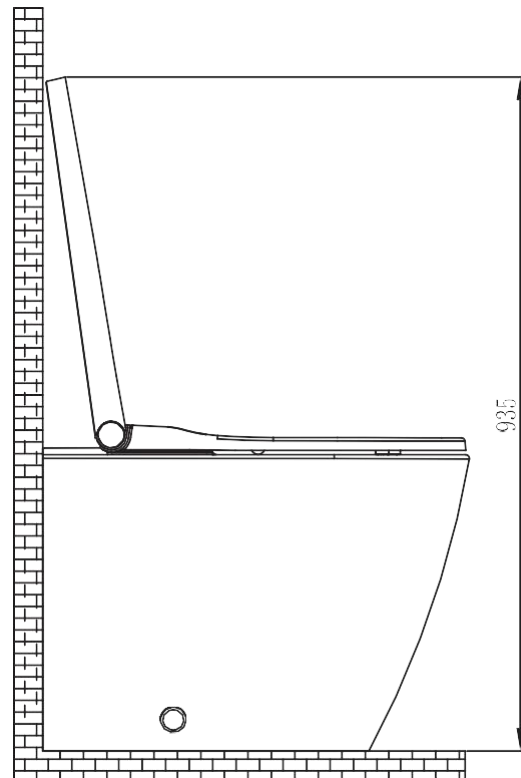
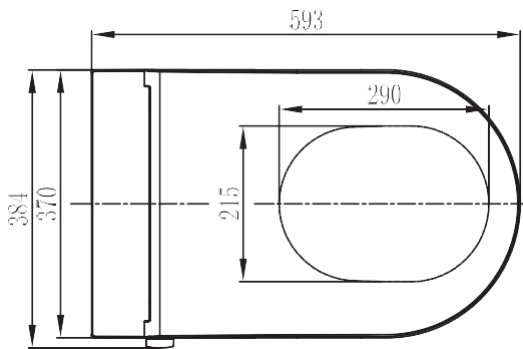
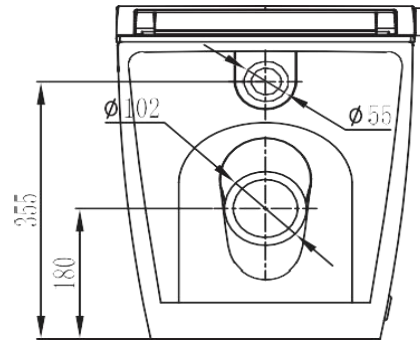
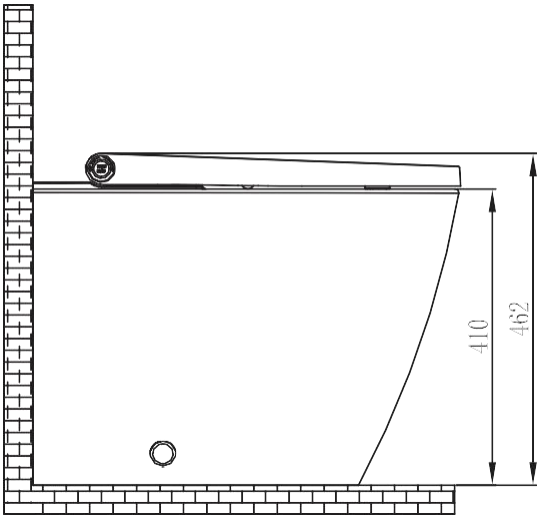

# PARTS LIST



Toilet (Qty. 1)



Remote (Qty. 1)  
(Batteries not included)

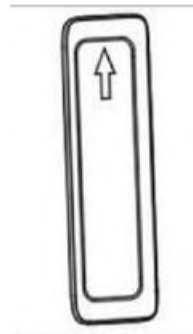

Remote Control Holder (Qty. 1)



Electrical Cable Coupler (Qty. 1)



G3/8-“1/2”  
Flexi Hose (Qty. 1)



Flow Limiter (Qty. 1)



Stop Valve (Qty. 1)



Filter (Qty. 2)

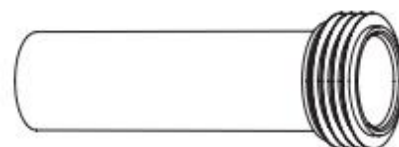

Flush Pipe and Seal (Qty. 1)

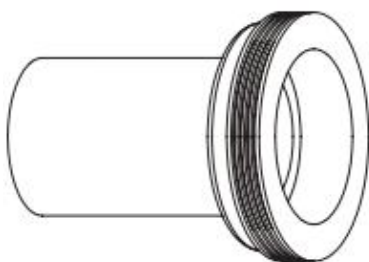

Waste Pipe and Seal (Qty. 1)

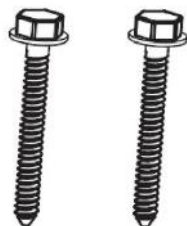

Floor Screws (Qty. 2)

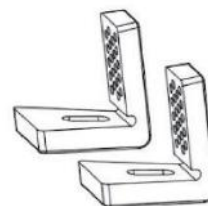

Floor Fixing Brackets (Qty. 2)



Screw Cover Holder (Qty. 2)

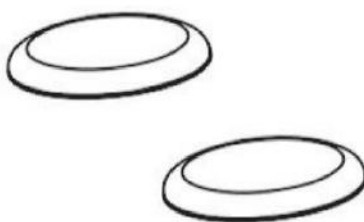

Decorative Cover (Qty. 2)

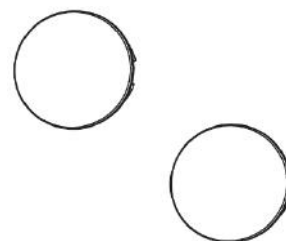

Decorative Screw Cover (Qty. 2)



Wall plug (Qty. 2)



Side Fixing Screw (Qty. 2)

**NOTE:** Screws and plugs supplied are for masonry walls only; for any other structure, a suitable plug and screw must be used.

## TOOLS REQUIRED

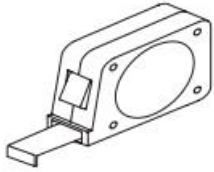

Tape Measure



Pencil



Phillips Screwdriver

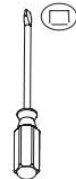

Flat Head Screwdriver



Knife



File



Adjustable Wrench



Wire Stripper



Electric drill



12mm Diameter drilling bit



Hacksaw

Ruler

Levelling instrument

Sealant

# PRODUCT OVERVIEW

**NOTE:** Images are for illustrative purposes only, as the product is subject to continual improvement.

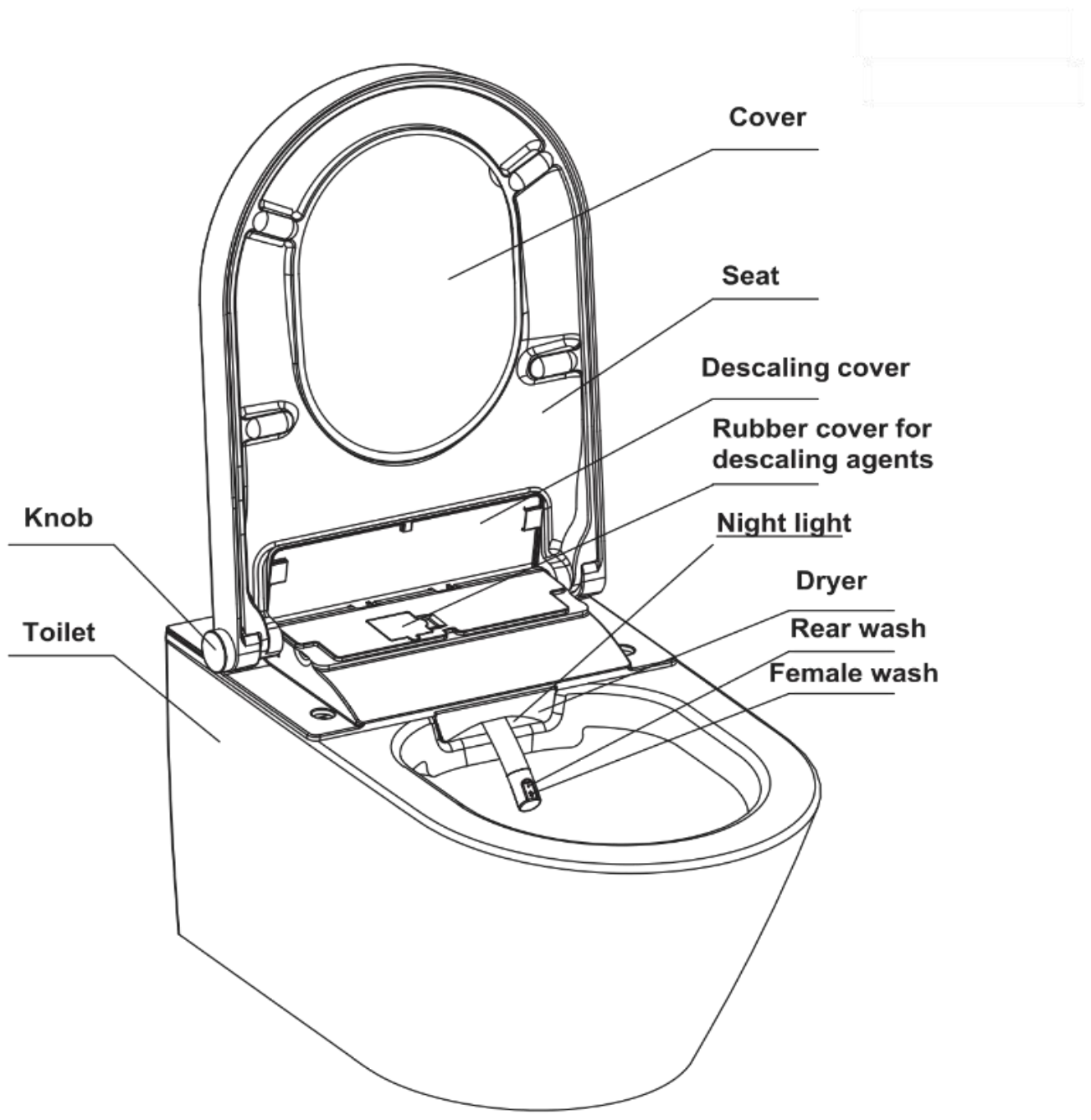

## BEFORE INSTALLATION

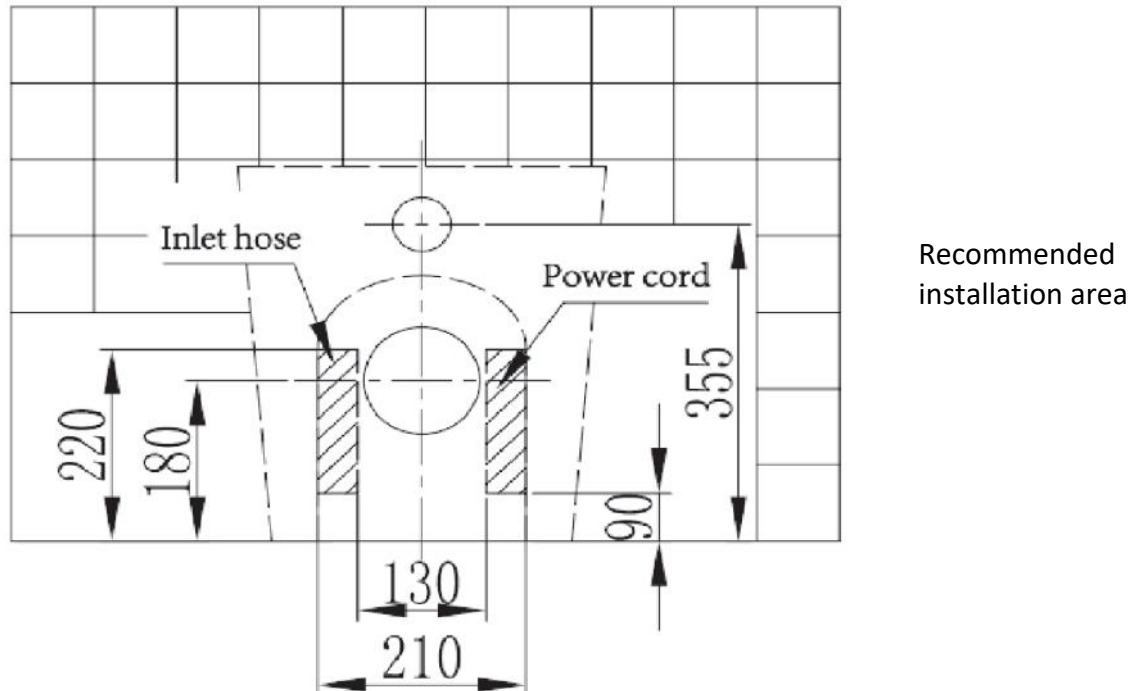

### IMPORTANT!

**Before commencing installation, the water and electrical supplies should be turned OFF.**

Please note that with your floor-mounted toilet, a Flush Pipe and a Waste Pipe are supplied; these may not be required, as they depend on the cistern to which the toilet is being connected and the position of the soil stack.

If you are fitting the toilet to a Better Bathrooms concealed cistern, the flush pipe supplied with the toilet will not be required, as it is included in the concealed cistern package and can be cut to fit.

If your current soil stack comes up from the floor, the waste pipe supplied with the toilet will not be suitable. A waste pipe to suit your application should be purchased.

Before attempting installation, ensure you have all the required tools and fittings to ensure a successful installation.

## INSTALLATION INSTRUCTIONS

Prepare the wall or unit against which the toilet will be installed to provide access for the water, cable, flush, and waste pipes.

Prepare the water supply pipe with a 1/2" female connector and electrical 3 core cable (which should be connected to a 13-amp fused spur or isolation switch outside the bathroom) as per below, allowing for 200mm of water supply pipe and 400mm of electrical cable to extend beyond the surface against which the toilet will sit, to allow connection to the toilet unit..

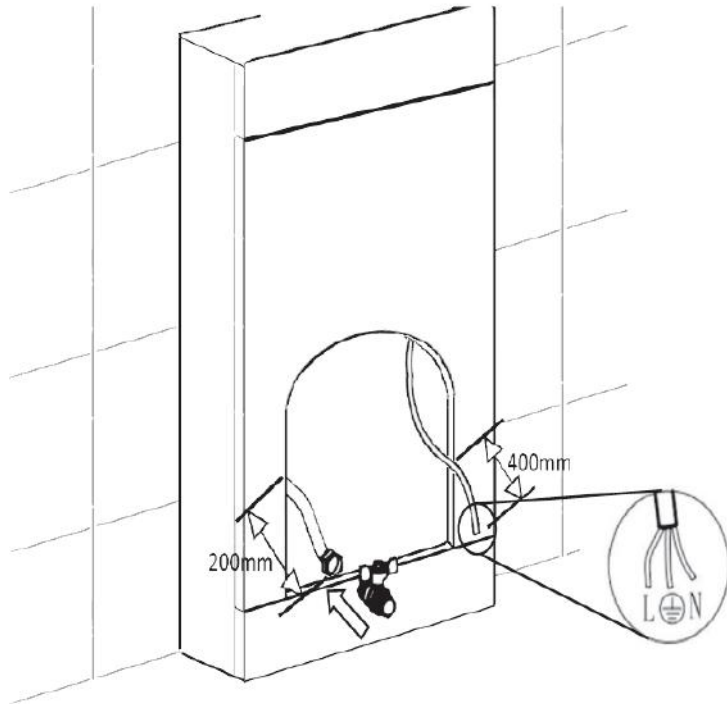

The installation shown is for a back-to-wall toilet with a WC unit.

For which you will remove the unit's front panel and cut out the area to accommodate the pipe and cable, using the "Recommended Installation Area" shown on the previous page.

Connect the stop valve to the pipe end, ensuring it fits snugly and is tightened with a spanner. Once connected and fully tightened, place a bucket under the stop valve, open the stop valve and flush the pipe for at least 10 seconds to remove any debris in the system.

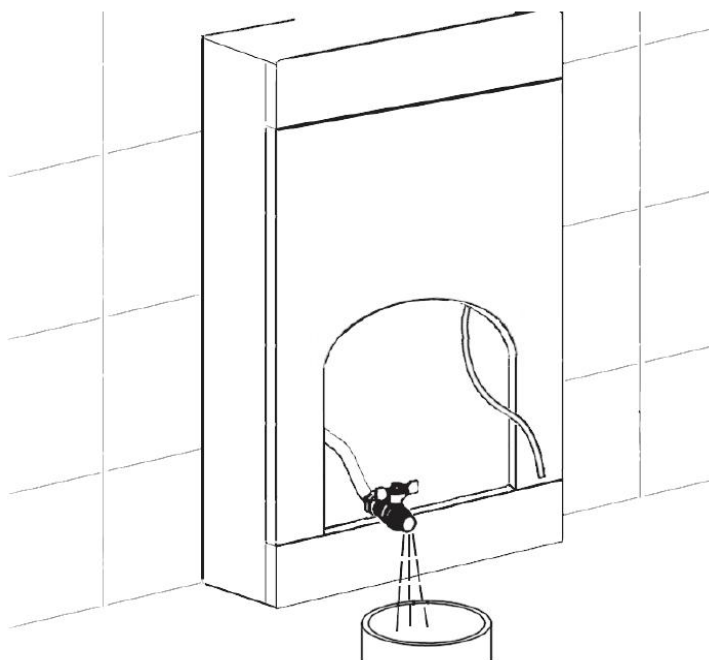

Once flushed through, turn the stop valve to the closed position.

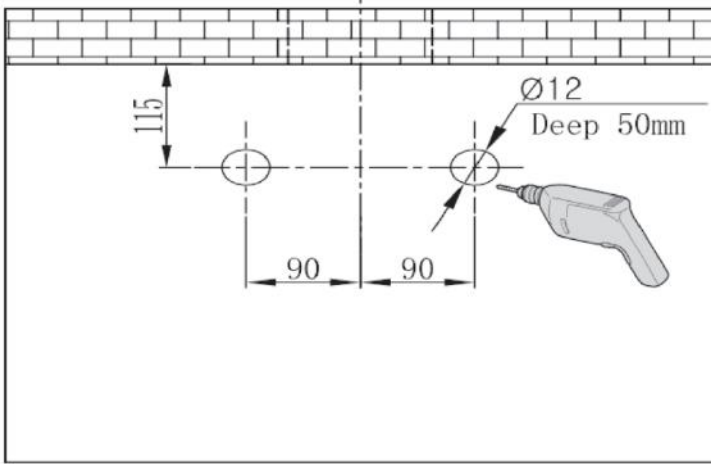

Using a 12mm drill bit, drill two holes in the floor using the dimensions shown below. When drilling into a tiled surface, it is recommended to use tape at the drilling location to prevent the drill bit from slipping. Ensure no pipes/cables are running under the floor in the drilling location.

Insert the 2 wall plugs into the holes drilled in the previous step. Attach a floor fixing bracket to either side using a hexagonal screw through the hole on its base.

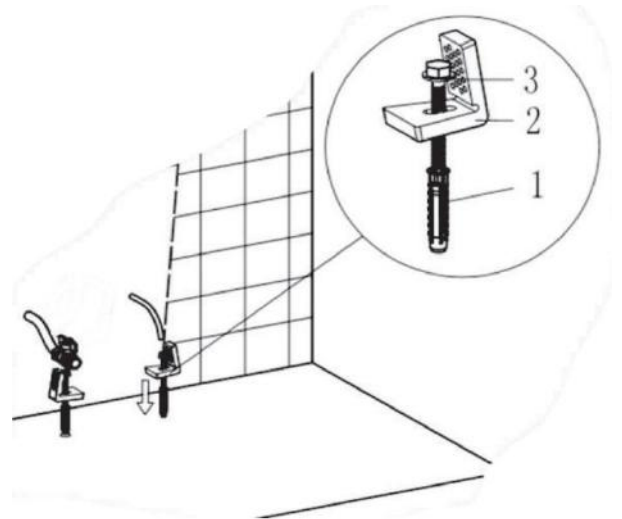

Tighten the hexagonal screws with an adjustable wrench.

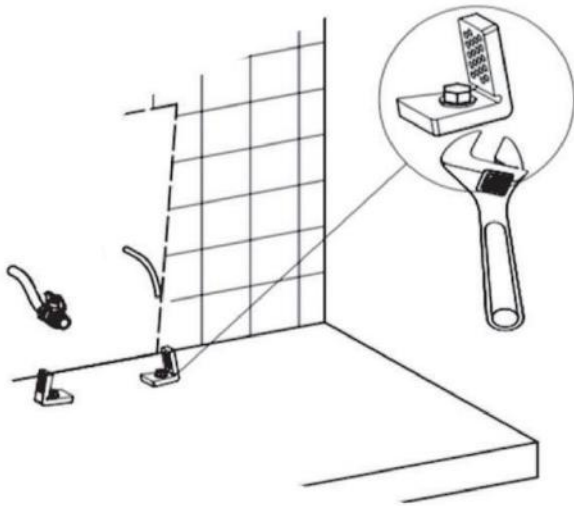

Connect the 1/2" female threaded end of the Filter to the Stop Valve, ensuring to fit the seal provided and tighten.

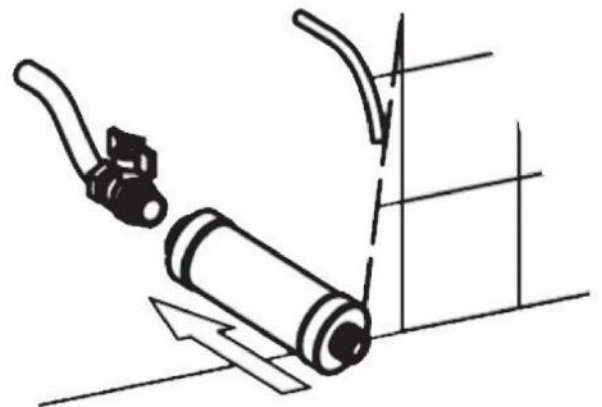

## FILTER INSTALLATION

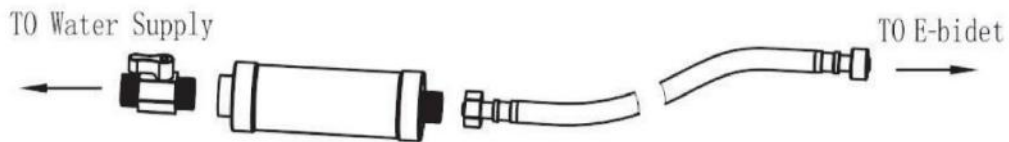

The required water supply pressure is 0.7-7.5 Bar as stated in the technical specifications. Check the water supply when connecting the filter.

To meet the 0.7 bar water supply, there should be 1.5L (3 bottles of water, 500ml) within 60 seconds. Please note that this is after the filter is installed. If this is not met, water flow must be increased.

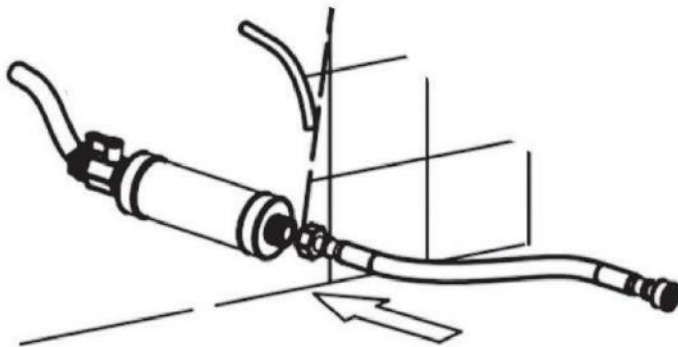

Connect the 3/8" - 1/2" Flexi Pipe to the Filter, ensuring to fit the seal provided and tighten using a spanner, do not over-tighten as this could crack the plastic body of the Filter.

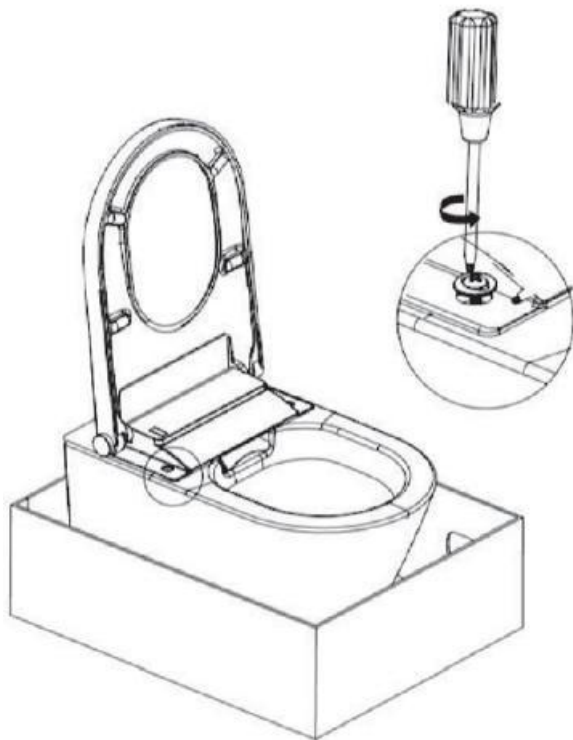

Remove the screws on the seat, using a cross-head screwdriver, ensuring not to lose the screws once removed.

Pull the seat from the toilet pan (Ensure the seat is not turned upside down).

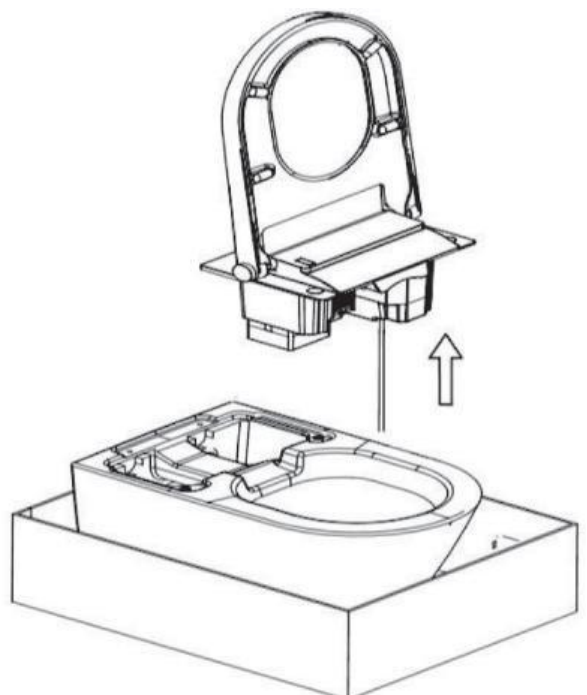

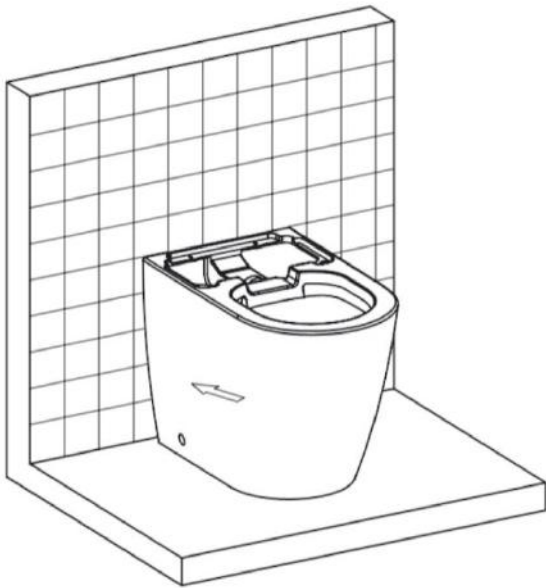

Push the toilet base into position against the wall, ensuring that the waste and flush pipes on the rear are fully engaged to create a full seal.

Pull the flexi pipe and electrical cable through to connect to the seat unit.

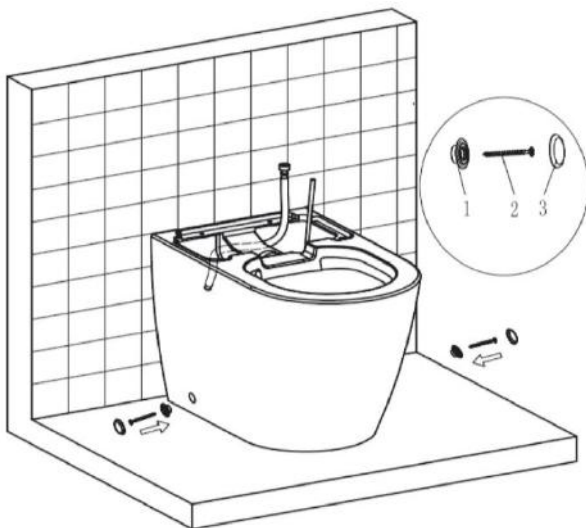
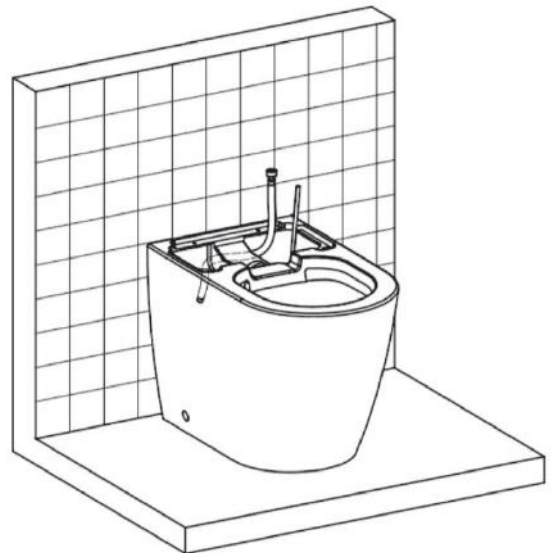

Insert the side fixing screws through the cover holder before inserting the screws through the side of the toilet, ensuring it engages with the fixing bracket secured to the floor.

Tighten until secure, then push the cover cap down.

Strip the end of the household cable to expose the wires for connection to the coupler.

When stripped, tidy the ends and connect to the coupler as shown, ensuring the screws are tightened and the wire ends are fully secured.

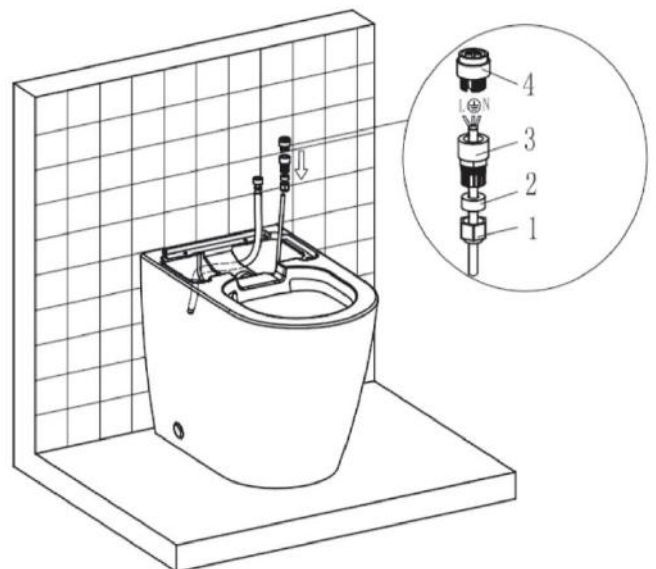

Follow the same process for the cable attached to the toilet, then connect the coupler sections together.

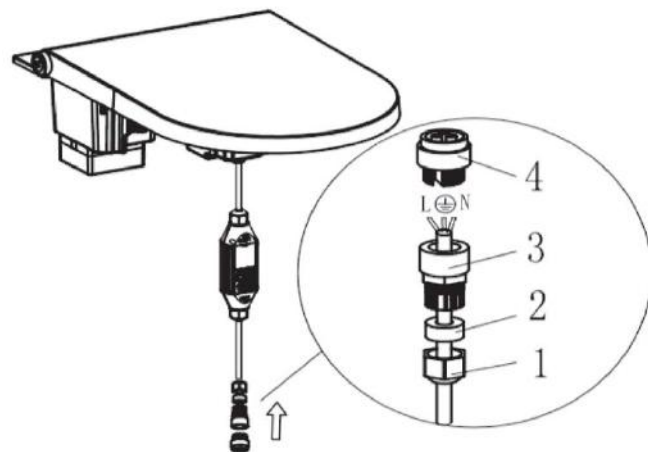

Connect the end of the water supply flexi pipe to the tank inlet on the underside of the toilet lid. This will require a firm push to connect the flexi to the inlet.

Once fully inserted and secure, tighten the nut. Before replacing the seat, turn on the water supply, the stop valve and the electrical supply.

After turning on the water and electrical supplies, you **MUST** carry out the RCD test. Instructions for this are printed on the rear of the RCD. A leak check must also be conducted on all water connections.

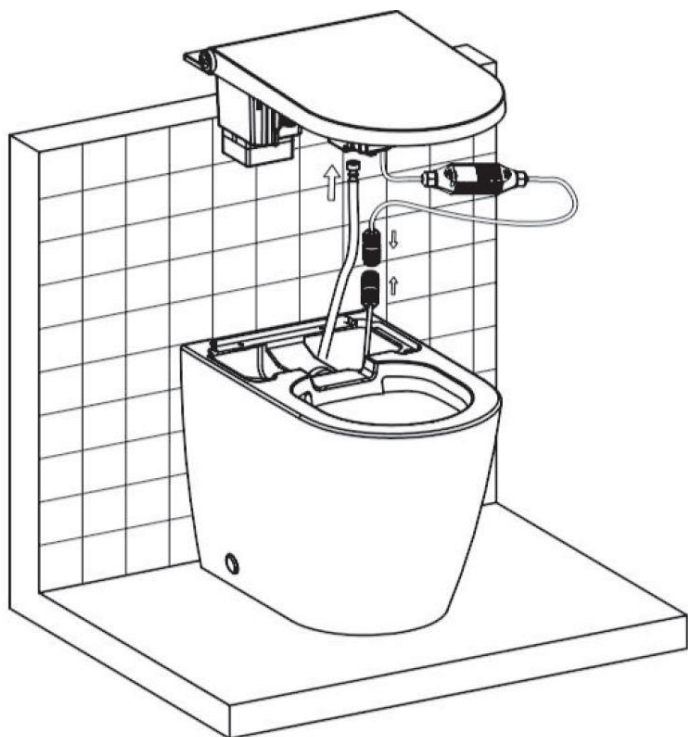

If the water volume in the flushing system is too high and splashes over the rim, a flush rate limiter is necessary. If, after installing the limiter, the bowl does not fully empty/clean, cut off one or more teeth of the limiter.

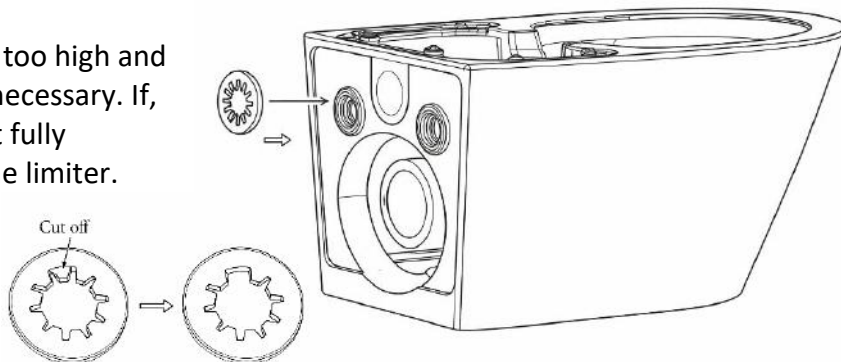

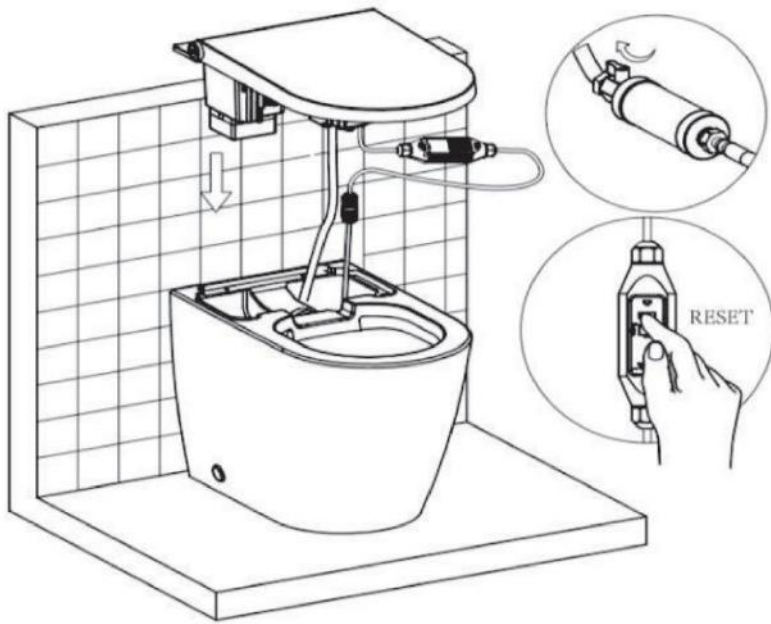

When checks are satisfactorily completed, the lid assembly can be re-fitted to the pan, and the flexi pipe and cables can be carefully fed under the pan. While doing this, be careful not to trap or kink the pipe or cable.

Locate the seat onto the pan and push down at the rear (not in the middle), as this could crack the seat.

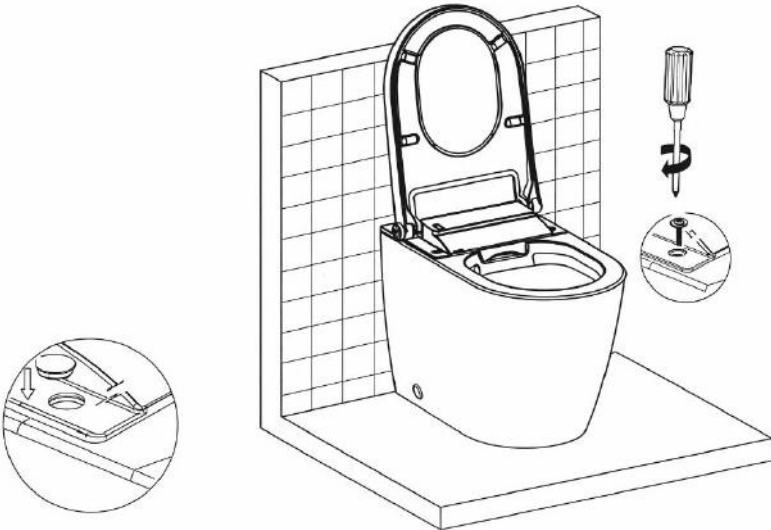
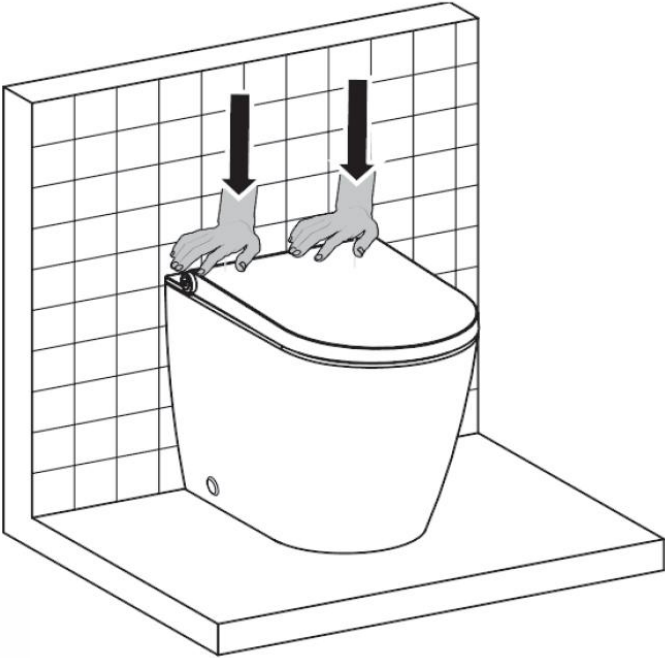

When the seat is located, re-fit the seat screws and tighten until secure, then fit the cover caps.

## INSTALLATION OF REMOTE HOLDER

Clean the wall surface where the remote-control holder will be installed. Ensure the surface is completely dry before installation.

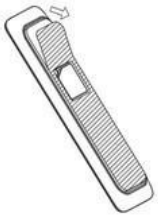
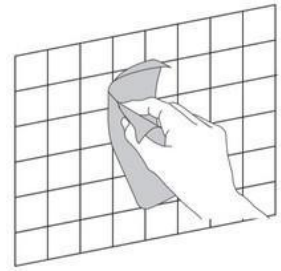

Peel off the adhesive strip cover from the rear of the holder.

Position the holder against the wall with the adhesive side facing the surface. Ensure it is level, then press firmly and hold in place for a few seconds.

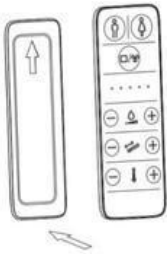
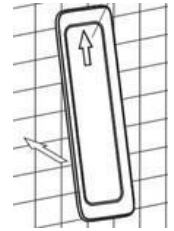

Once securely fixed, place the remote control onto the holder. The built-in magnet will keep the remote securely in place.

## REMOTE CONTROL

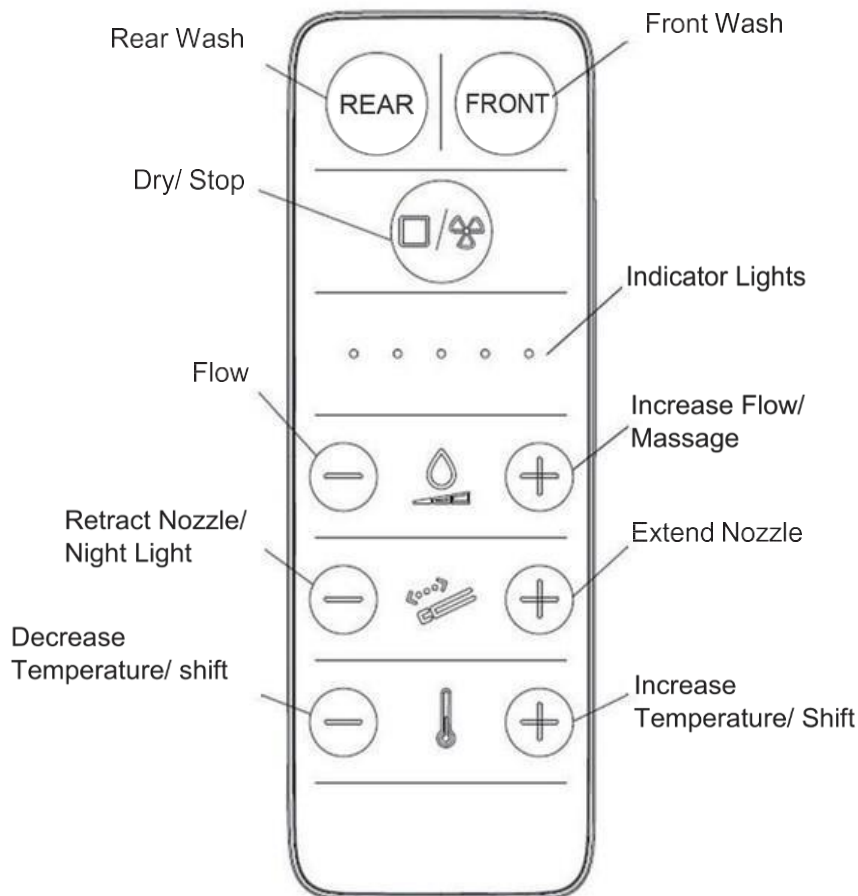

## FITTING / REPLACING THE BATTERIES

- Do not mix different types of batteries, or new and used batteries.
- Insert batteries with the correct polarity, as indicated.
- Remove exhausted batteries and dispose of them safely.
- If the appliance will not be used for an extended period, remove the batteries.

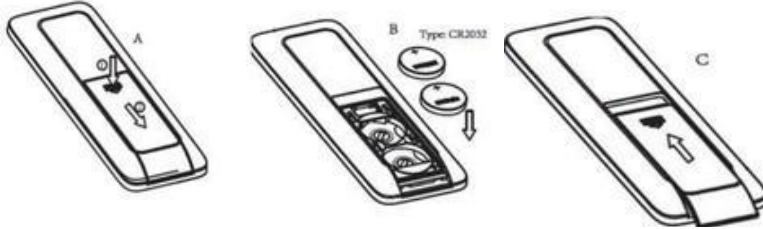

**NOTE:** Batteries not supplied. The remote requires 2x 3V CR2032 batteries.

When the light flashes continuously, the batteries need to be replaced.

## WASH OPERATION

- Always be seated when using the toilet wash operation.
- Before the wash spray commences, a clean operation will take place and water will run from under the nozzle for a few seconds, then extend and spraying for the wash will commence.

Press the "**Wash**" button on the remote control, and it starts to wash. It will automatically stop after 3 minutes, or you can stop washing by pressing the "**Stop**" button.

**REAR**  
Rear wash

**FRONT**  
Front wash

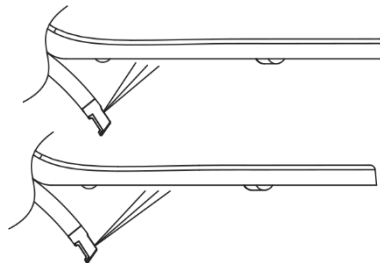

### OR

You can operate by rotating the dial. Rotate the dial in the clockwise direction to activate "**Female wash**" and the anticlockwise direction for "**Rear wash**". It will stop after 3 minutes. You can stop washing before this by pressing the "**Stop**" button.



**NOTE:** Once your product is installed and all water and electrical supplies are connected and operational, your toilet is ready for use. Lift the toilet seat lid and sit down so the sensor detects a user.

Press the wash button; the toilet will initially run an automatic nozzle self-clean for about 9 seconds, then the wash (for the user) will commence. When you stop the wash, the toilet will self-clean for around 9 seconds. When the wash mode is activated, after a 10-second delay, the nozzle will move for 18 seconds before staying in the set position for the rest of the wash.

While in wash mode, you can adjust the following settings:

### MESSAGE OPERATION

**In the process of Rear or Female washing:** Hold either the "+" or "-" temperature button on the remote control, then repeatedly press the "+" flow button to cycle through the massage modes.

- **Normal:** When one indicator light is on.
- **Oscillating:** When two indicator lights are on.
- **Pulsating:** When three indicator lights are on.
- **Oscillating + Pulsating:** When four indicator lights are on.

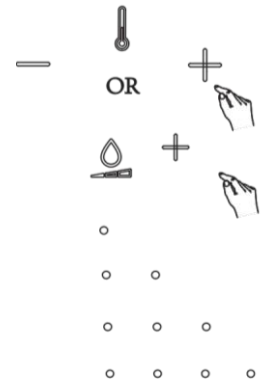

### WATER FLOW

Change between LOW, MEDIUM or HIGH

To adjust the water flow, press the **+ or - water flow buttons** on the remote. The indicator will show the rate of water flow as **LOW, MEDIUM, or HIGH.**

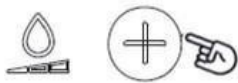

**Alternative Adjustment:** You can also adjust the water flow using the **dial located on the side of the toilet.** Turn the dial clockwise to increase the flow, or anticlockwise to decrease it.

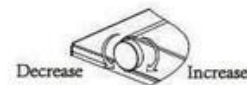

### WATER TEMPERATURE ADJUSTMENT

**Change between LOW, MEDIUM or HIGH:** To adjust the water flow, press the **+ or - water flow buttons** on the remote. The indicator will show the rate at which water is flowing as **LOW, MEDIUM, or HIGH.**

**Alternative Adjustment:** You can also adjust the water flow using the **dial located on the side of the toilet.** Turn the dial clockwise to increase the flow, or anticlockwise to decrease it.

### STOP



**Stops all functions immediately,** no matter where they are in their cycle. To stop any function at any time, press the stop button on the remote control.

### ADJUST NOZZLE



The nozzle position controls where the water is sprayed during washing mode. Use the **+ and - nozzle buttons** on the remote to retract or extend the nozzle.

**NOTE:** The nozzle position can **only be adjusted using the remote control.**

## AIR DRY MODE

When seated, press the **Dry** button on the remote, and the air-dry mode will operate for 3 minutes. This mode does not operate during the "Rear" or "Female" washing process.



**While the air-dry mode is operating, you can change the following settings:**

### AIR TEMPERATURE ADJUSTMENT

During drying, adjust the air temperature using the "+" and "-" temperature buttons on the remote.



**Side Dial Method:** Hold the dial on the side of the toilet while rotating it. The air temperature will increase clockwise and decrease anticlockwise.



### STOP



**Stops all functions immediately**, no matter where they are in their cycle. To stop any function at any time, press the stop button on the remote control.

### BREATHING LAMP SETTING

The indicator light on the control dial is **on by default**.

**To turn off via remote:** Hold the "+" or "-" temperature button on the remote, then short-press the "Rear" washing button. The breathing lamp will be turned off and will relight when the process is repeated.

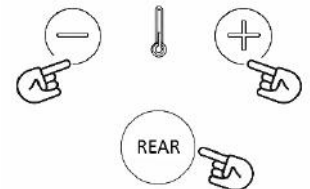

**NOTE:** If the dial light flashes slowly (once every 2-3 seconds) during normal use, this does not indicate a fault.

To turn off via dial light: Open the cover and sit (without washing or drying), then hold the control dial for 6 seconds. The lamp will turn off; if held for 6 seconds again, the light will turn back on.

## OTHER FEATURES

The intelligent toilet features other features that enhance its ease of use. These can be adjusted when **no other function is in operation**.

### NIGHT LIGHT

The night light defaults to **always on**.

**Remote Adjustment:** Hold the "+" or "-" temperature button on the remote control and simultaneously short-press the "-" nozzle button to change between **OFF, ON and SMART modes** (the light will operate in dark conditions).

- **Close mode:** when one indicator light is on.
- **Always on mode:** when two indicator lights are on.
- **Smart mode:** when three indicator lights are on.

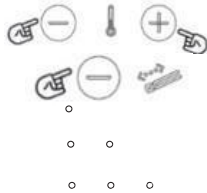

Alternatively, the night light can be adjusted by lifting the toilet lid and seat. Turn the control dial on the side of the seat **anticlockwise** to change the mode between "close", "always on", and "smart".

### AUDIO

The sound is **on by default**, and the bidet will beep when settings are changed.

**To turn off the sound via remote:** Hold the "+" or "-" temperature button on the remote, then short-press the "Front" washing button. Press it again to turn the sound back on.

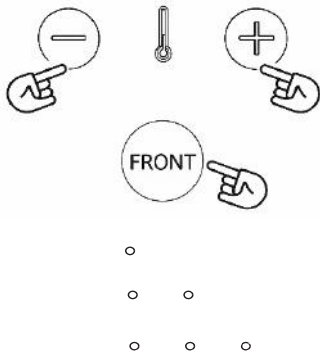

**Indicator Modes:**

- **Off mode:** when one indicator light is on.
- **On mode:** when two indicator lights are on.

**To turn off via dial:** Open the cover and seat, hold the control dial and rotate it at the same time. The sound will activate when turned clockwise and **deactivate when turned anticlockwise**.

### STANDBY

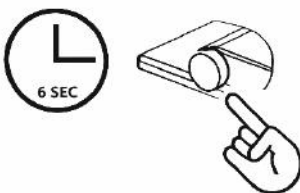

Without sitting, press and hold the control dial on the side of the seat for **6 seconds**; the seat will enter "**Standby Mode**".

Press and hold the button again for 6 seconds to **restart the seat**.

## REMOTE CONTROL SYNC

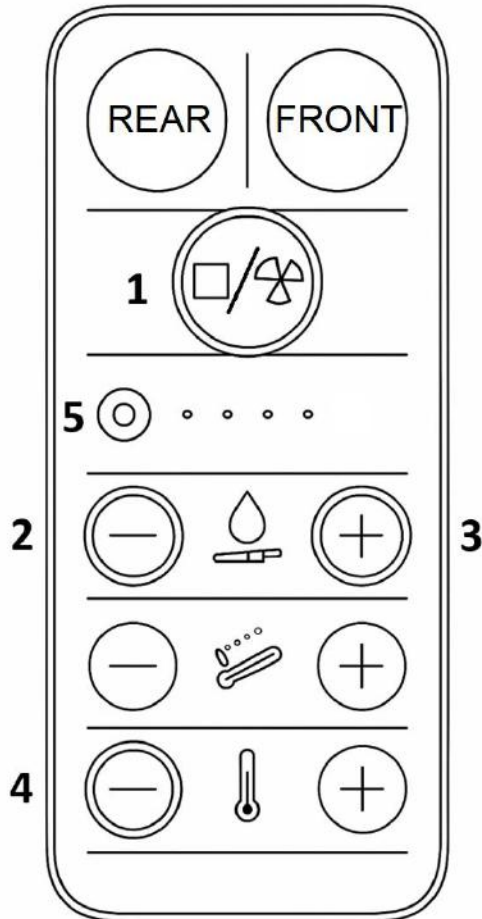

**Step 1:** Open the lid and the seat. Turn off the night light using the side control (refer to the "light Setting").

**Step 2:** Press and hold the **STOP** button (1) and "-" button (4) simultaneously for a few seconds until the **first light (5) flashes**.

**Step 3:** Release the **STOP** button (1) but **continue pressing the "-"** button (4).

**Step 4:** While still pressing the "-" button (4), press the "-" button (2), then the "+" button (3), and finally release the "-" button (4). The indicator lights will flash, and you will then know the **toilet's ID code** by referring to the table below. The remote is then synced with the toilet.

A few seconds later, all the lights will turn off, and you can start controlling the toilet.

**For multi-installations:** When you finish the above four steps, you can press the "-" button (2) and "+" button (3) to **change the ID code** for the toilet. There are 5 lights, but only the **first 4 lights** indicate the ID code as follows:

**Key:** ● Not Illuminated | ○ Illuminated

LIGHT SHOWING	ID CODE NO
○ ● ● ●	0
● ○ ● ●	1
○ ○ ● ●	2
● ● ○ ●	3
○ ● ○ ●	4
● ○ ○ ●	5
○ ○ ○ ●	6
● ● ● ○	7
○ ● ● ○	8
● ○ ● ○	9

## REPLACING THE FILTER

The filter supplied has a life of 6 months and should be replaced to prevent reduced flow. This can be affected by water type, e.g., hard water areas.

To replace the filter, you will need to turn off the power supply, the water supply, and the seat will need to be removed.

Once the power has been cut to the unit, unscrew the seat from the toilet; do not turn the seat upside down. Once removed, access the filter and the stop valve.

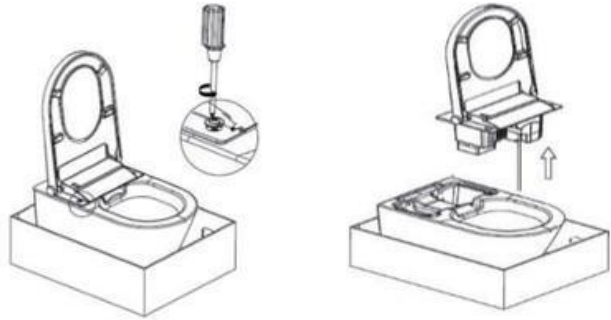

Turn the stop valve to the closed position.

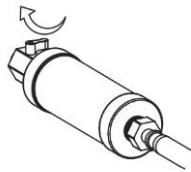

Disconnect the filter and replace with the new part, ensuring to re-fit the seals.

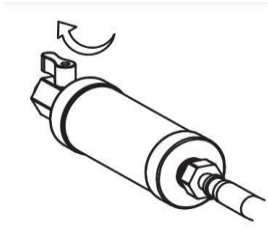
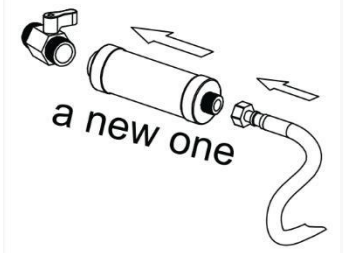

Feed the pipes back into the toilet base, turn the power back on and reset the RCD.  
Re-open the stop valve.



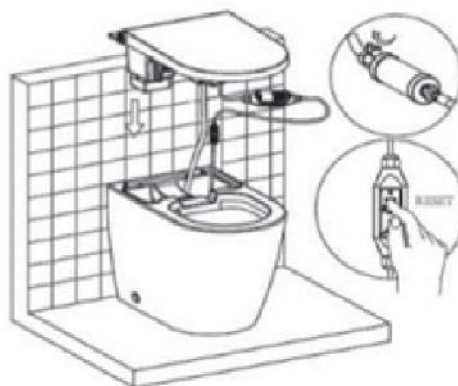

Re-fit the seat and secure it into position.

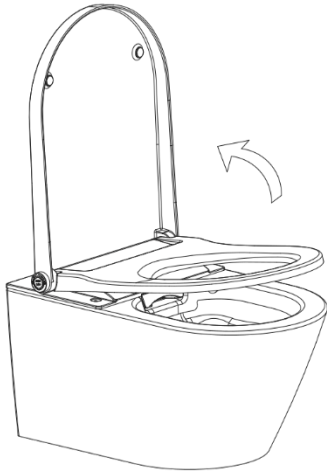

## DESCALING THE DEVICE

- You will need to descale the device at least once a year, or more often depending on the number of shower cycles and the water quality in your environment.
- During the descaling procedure, you can continue to use the toilet without the shower functions.
- The descaling procedure lasts up to 30 minutes. During this time, the blue LED light always flashes, and the device makes a sound. Once the blue LED switches off, the spray functionality is ready for operation again.
- Please use descaling agents of less foam.

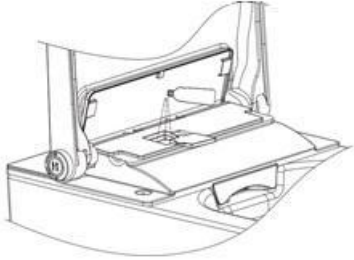
**CAUTION:** Damage to the human body and the device from aggressive descaling agents

<p>1. Open the cover and seat.</p> 	<p>2. Open the descaling cover.</p> <p><b>NOTE:</b> Water is flowing from the nozzle at this time. When the device bleeps twice, it means you can pour the descaling agents.</p> 
<p>3. Open the rubber cover.</p> 	<p>4. Pour descaling agents. Dosage: about 150ml.</p> 
<p>5. Close the rubber cover and descaling cover.</p> 	<p>6. Close the rubber cover and descaling cover. Then it will start the descaling procedure. During the descaling procedure, you can continue to use the toilet without the shower functions. It will last for about half an hour. During this time, the LED of the dial will flash. Once the LED stops flashing and resumes the breathing light, and with a long "BI", the spray functionality is once again ready for operation.</p>

## DRAINING THE WATER TANK

The water and power must be cut to the unit before work is started. Do not invert the seat. Ensure a water-holding container is in place before draining.

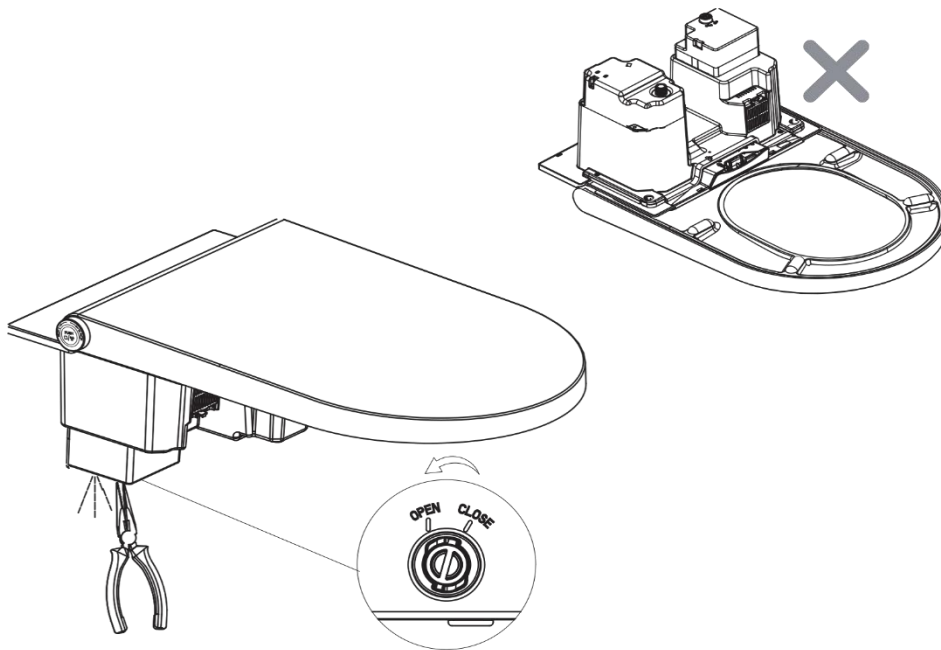

Using pliers, hold the plug on the tank, turn it to OPEN, and pull it out. Water will start to drain. After draining is completed, insert the plug and turn to CLOSE.

## ONE-ON-ONE SETTING

To control specific electronic bidets when multiple units are installed in the same area, follow these steps:

1. Open both covers and seat and remain unseated.
2. On the remote, simultaneously press and hold the "stop" button and "shift" button to adjust the temperature until all five lights are on and the first indicator light flashes.
3. Release the "stop" button, but continue pressing the "shift" button.
4. Press the "-" and "+" of the flow in order, then release the "shift" button; the lighted indicator now shows the current ID code.
5. Use the "-" and "+" flow buttons to change the ID code; there are 32 ID codes in total, with the first code set as the default.

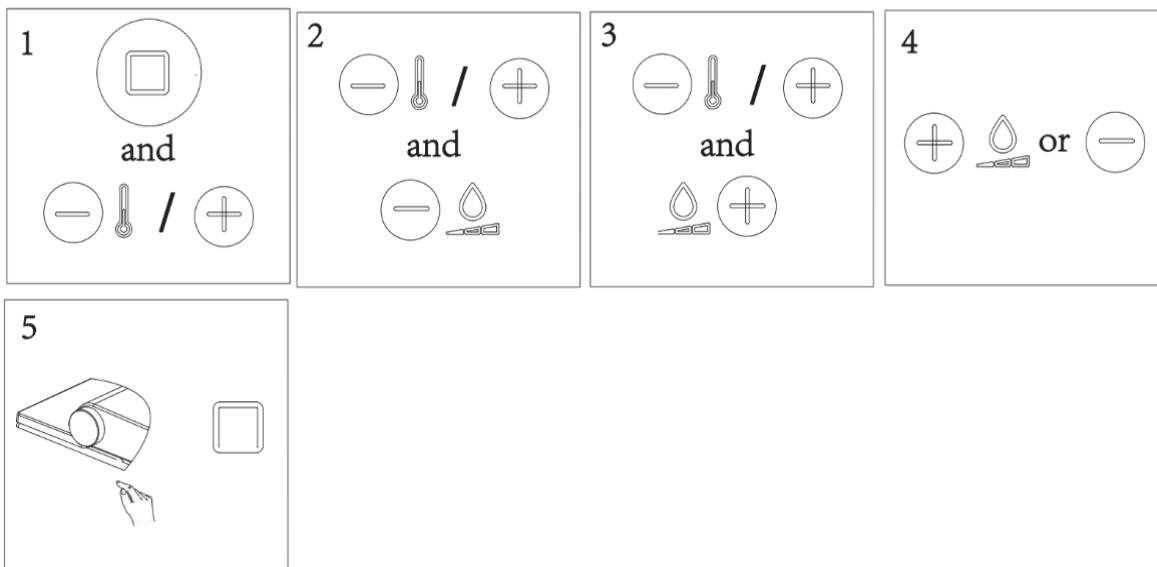

## ALTERNATIVE MATCHING METHOD:

1. Hold the "female wash" button on the remote for approximately 5 seconds until the indicators light up in turn, and a short beep is heard.

FRONT 

2. Press and release the "Stop" button on the bidet seat; the remote indicators will stay on for 2 seconds, and a long beep will confirm successful matching.

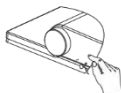

## RESTORE FACTORY SETTINGS AND BATTERY REPLACEMENT

### RESTORE FACTORY DEFAULT SETTINGS

- Remove and reinstall the batteries from the remote control; five indicators will turn on.
- Hold the "stop" button on the remote; the five indicators will turn on in turn.
- Release the button, and the factory default settings are restored.

### REPLACE THE BATTERIES

- The remote control requires 2 x 3V CR2032 batteries. (Not supplied).
- Replace batteries immediately when the level light flashes continuously.

#### CAUTION:

1. Non-rechargeable batteries must not be recharged.
2. Rechargeable batteries must be removed from the appliance before charging.
3. Do not mix different types of batteries or new and used batteries.
4. Batteries must be inserted with the correct polarity.
5. Exhausted batteries should be removed and disposed of safely.
6. Remove batteries if the appliance will be stored unused for a long period.
7. The supply terminals must not be short-circuited.

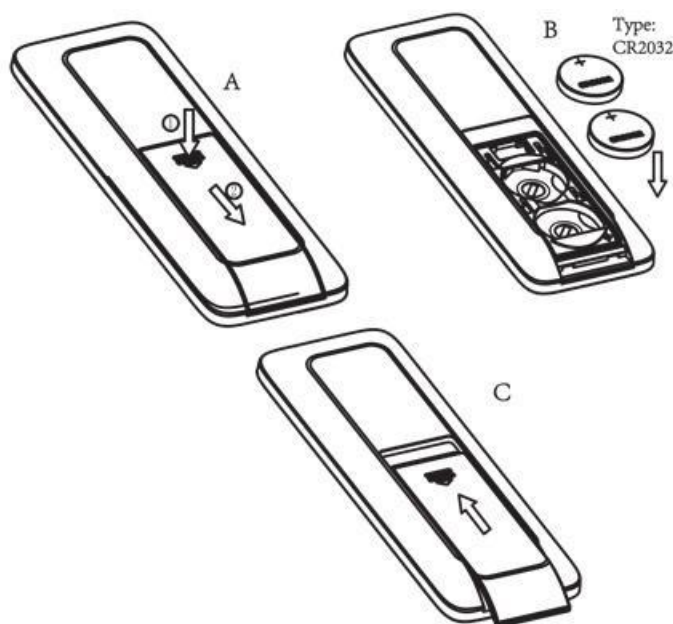

## PRODUCT MAINTENANCE

### CARE AND CLEANING

Maintaining interval	Maintaining activity
Daily	Remove water drops with a soft, lint-free cloth to avoid limescale build-up.
Weekly	Clean all surfaces and corners. Clean the spray nozzle if required. See "Nozzle cleaning".
Monthly	Clean the WC ceramic appliance with a low acidic cleaning agent.
Every half year	Replace the filter if required.
Every year	Descale the device. See "Descaling the device".

**NOTE:** Do not use strong abrasive cleaning agents or materials, as this can damage the product and will invalidate your guarantee.

### TANK SELF-CLEAN

If the product is not used for more than 72 hours, the next time it is used and the wash function is activated, the unit will carry out a self-clean for approximately 3 minutes. All functions will be deactivated during this time.

### CLEANING THE NOZZLE

It is recommended to regularly clean the nozzle to prevent blockages. To manually clean the nozzle, follow the steps below:

- Open the seat cover and seat, then rotate the control dial clockwise.
- The nozzle will extend; rub clean with a brush to clean the nozzle holes, and then wipe clean.
- The nozzle will return after 5 minutes, or you can press the Stop button.

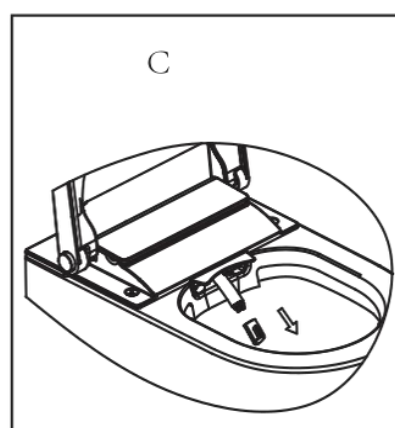
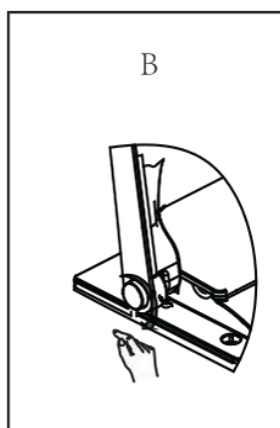
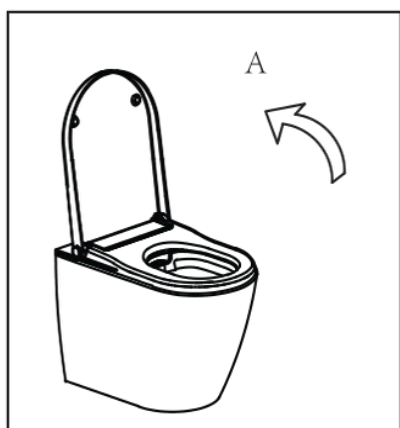

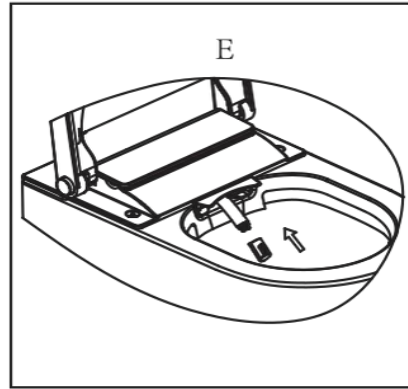
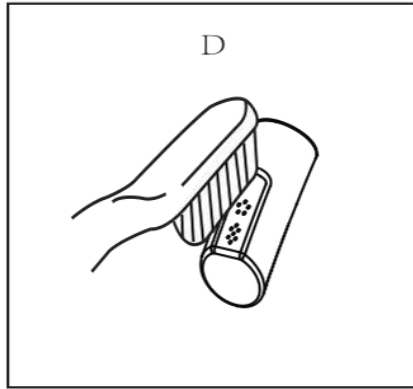



## TROUBLESHOOTING

Problem	Potential cause	Suggested action
The washing function is not operating.	The power supply may not be connected.	Ensure the power switch is in the on position and the RCD has been reset.
	The water supply may be disconnected.	Ensure the inlet water valve is in the open position, and ensure there is adequate water flow to the unit.
	The filter may be blocked.	Please replace the filter. It has a service life of approximately. 6 months.
	Seat detector not activated.	Ensure the seat is occupied to activate the function.
	The toilet lid is closed.	Lift the toilet seat.
	Function not used for more than 72 hours.	The self-cleaning function will activate, which takes around 3 minutes. During self-cleaning, all the buttons are deactivated until the function has completed.
	The seat assembly is not connected to the water supply.	Check that the seat assembly has a connected and flowing water supply, as the cistern filling does not supply water to the seat.
The washing function suddenly stops, and the nozzle retracts.	The washing cycle is 3 minutes. The nozzle will stop spraying after 3mins, and then retract.	This is normal, and please press the "wash" button to start another wash cycle.
	Water supply interrupted	Please check if there is a water outage.
	The seat detector has sensed that the user left the seat	Please adjust your sitting position
	The toilet lid is not fully open	Ensure the lid remains upright during the function.
Low water flow rate	The water flow rate may be set at low grades.	Please increase the flow rate as per the "adjusting water flow rate" of the operating instructions.
	The water supply pressure may be too low	Please check and ensure the water supply pressure is 0.07Mpa
	The filter may be blocked.	Replace the filter. It has a service life of approximately. Half a year
	The nozzle may be blocked.	Please replace the nozzle.
Low water temperature	The water temperature may be set at a low temperature.	Please set the water temperature to high grade as per the "adjusting temperature "of the operating instructions.
	The temperature of the water supply is too low	Please set the water temperature at high grade as per "adjusting temperature "of operating instructions, or decrease the flow rate as per "adjusting water flow rate".
The nozzle comes out slowly.	Upon starting the washing function, the nozzle will be in self-cleaning mode before coming out.	This is normal
The water flows out, but the nozzle does not come out	The toilet has not used for more than 72 hours	This is normal. If not used for more than 72 hours, when the unit starts, it will begin the self-cleaning for about 3 minutes.
The dryer cannot work.	The power supply may not be opened	Please turn on the power
	Not correctly seated	Please sit on the seat and adjust your sitting position.
	The cover is closed.	Please open the cover and sit on the seat.

Low air temperature	The air temperature may be set at low grades	Please set the air temperature at high grade as per "adjusting temperature "of operating instructions
	The air heater is not working normally	Please contact the local distributor
The night light is always off.	Too much light in the surrounding environment.	When the night light is set to smart mode, the night light will not work in a bright environment.
	The night light function may be closed.	Please open the night light function and adjust the night light mode as per "Light Setting".
The night light is always on.	1. The environment is dark.	When the night light is set to smart mode, the night light will always be on when in a dark environment.
	2. Something may be covering the control dial.	Remove the obstructions around the control dial
	3. The night light may be set to 'Always On' mode	Please adjust the night light mode as per the "Light Setting" of the operating instructions
The nozzle goes back automatically during manual cleaning.	The nozzle goes back after washing for 5 minutes	This is normal
	Press the "stop" button.	Manual cleaning will be stopped if you press the control dial or press the "stop" button on the remote control.
	The seat detector senses that the seat is closing	Please do not put down the seat during manual cleaning
The remote control is not functioning.	There are no batteries in the remote control	Please install the correct batteries in the remote control
	Maybe the battery power is too low	When batteries are low, the LED will flash. Change the batteries
	Maybe the code of the bidet And a remote control is not the same	Please set the code of the remote control to the correct one. See "Remote Control Synch"
There are BEEP sounds when the bidet is operating	There is a short BEEP when you are sitting down, and a long BEEP when you leave. Also, there is a short BEEP when the bidet has received commands.	This is normal. You can turn off the sound. See "Sound Setting"
The bidet does not function normally.	Abnormal operation	Please shut off the power and turn it on after one minute. If the bidet still cannot work, please contact the local distributor.
The light around the control dial flashes twice with constant BEEP	The water supply temperature may be too high	Please shut off the power and water supply, stop using the product, and then contact the local distributor.
The light around the control dial keeps flashing	There may be something wrong with the product	Please shut off the power and water supply, stop using the product, and then contact the local distributor.

## BATTERY WARNINGS

 	<p style="text-align: center;"><b>BATTERY WARNING</b></p> <p><b>KEEP OUT OF REACH OF CHILDREN</b>          Swallowing can lead to chemical burns, perforation of soft tissue, and death. Severe burns can occur within 2 hours of ingestion. Seek medical attention immediately.</p>	
<p>If the battery compartment (if applicable) does not close securely, stop using the product and keep it away from children.</p> <p>If you think batteries might have been swallowed, or placed inside any part of the body, seek immediate medical attention</p>		
<p style="text-align: center;"><b>THERE MAY BE NO OBVIOUS SYMPTOMS OF BATTERY INGESTION</b></p>		
<p>Unfortunately, it is not obvious when a button or coin battery is stuck in a child's oesophagus (food pipe). There are no specific symptoms associated with this. The child might:</p> <ul style="list-style-type: none"> <li>• Cough, gag or drool a lot;</li> <li>• Appear to have a stomach upset or a virus;</li> <li>• Be sick;</li> <li>• Point to their throat or stomach;</li> <li>• Have a pain in their abdomen, chest or throat;</li> <li>• Be tired or lethargic;</li> <li>• Be quieter or more clingy than usual or otherwise "not themselves";</li> <li>• Lose their appetite or have a reduced appetite; and</li> <li>• Not want to eat solid food / be unable to eat solid food.</li> </ul> <p>These sorts of symptoms vary or fluctuate, with the pain increasing and then subsiding.</p> <p>A specific symptom to button and coin battery ingestion is vomiting fresh (bright red) blood. If the child does this seek immediate medical help.</p> <p>The lack of clear symptoms is why it is important to be vigilant with "flat" or spare button or coin batteries in the home and the products that contain them.</p>		

# TECHNICAL SPECIFICATION

MODEL		PURMBBTW
Wash	Rear Wash	●
	Female Wash	●
	Massage	●
	Adjustable Water Temperature	OFF/5 Steps (Default 3rd)
	Adjustable Flow Rate	5 Steps (Default 3rd)
	Adjustable Spray Position	5 Steps (Default 5th)
Warm Air	Air Drying	●
	Adjustable Air Rate	-
	Adjustable Dryer Temperature	OFF/5 Steps (Default 3rd)
Heated Seat	Heated Seat	-
	Adjustable Seat Temperature	-
Hygiene	Deodoriser	-
	Nozzle Automatic Cleaning	●
	Nozzle Manual Cleaning	●
Descaling		●
User Mode		-
Remote Control		D81-03
Night Light		●
Breathing Lamp		●
Soft Closing Seat and Cover		-
Body Dial		●
Rimless Toilet		●
Installation of the toilet		Back to wall
Water Supply Connector		G 3/8
Rated Voltage		AC220-240V, 50/60HZ
Power		1170W
Length of Power Cord		1.8m
Water Supply Pressure		0.07~0.75MPa (0.7~7.5Bar)
Water Supply Temperature		4~35°C
Ambient Temperature		4~40°C
Protection Degree		IPX4
Wash Device	Flow Rate	350~650mL/min
	Water Temperature	31~39°C
	Wash Cycle Time	3 Minutes
	Heating Mode	Tank
	Maximum Heater Power	1200W
	Safety Device	Thermal Cutoff/ Fuses\Liquid Level Switch\Thermostat
	Backflow Prevention	Air Gap of AB type
Dry Device	Maximum Speed Of Air	≥4m/S
	Maximum Dryer Power	350W
	Dry Cycle Time	3 Minutes
	Warm Air Temperature	35~50°C
	Safety Device	Thermal Cutoff/ fuse\Thermostat
Deodorization	Deodorization Mode	Diatom
	Deodorisation Cycle Time	15Minutes
Heated Seat	Heated Power	-
	Seat Temperature	-
	Safety Device	-
Remote Control	Frequency Range	2460MHz
	Maximum RF Output Power	-10dBm
	Type of batteries	CR2032
	Number of batteries	Two pieces
Other Safety Device		Residual Current Devices
Net Weight		35 Kg
Dimensions		593*384*388 mm

## UK SUPPORT

Call: 0871 244 0935

Office hours: 9AM - 5PM Monday to Friday

[www.BetterBathrooms.com](http://www.BetterBathrooms.com)

Unit 2A, Trident Business Park,

Neptune way, Leeds Road,

Huddersfield, HD2 1UA

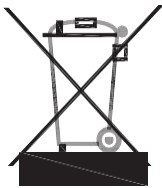

Recycling facilities are now available for all customers at which you can deposit your old electrical products. Customers will be able to take any old electrical equipment to participating sites run by their local councils. Please remember that this equipment will be further handled during the recycling process, so please be considerate when depositing your equipment. Please contact the local council for details of your local household waste recycling centres.

At the time of printing the product contains no substances listed within Annex XIV of the Reach Regulations (EC) 1907/2006. In accordance with Article 59 of the same regulation the following substances are contained within the product at permitted levels: Lead & Cadmium.

As a responsible manufacturer the regulations are monitored to ensure continued compliance. Further information can be provided upon request.

### ***For more information***

- visit [betterbathrooms.com](http://betterbathrooms.com)
- email [customerservices@buyitdirect.co.uk](mailto:customerservices@buyitdirect.co.uk)
- call 0330 390 3062
- write to Trident Business Park, Neptune Way, Huddersfield, HD2 1UA

**better**   
**bathrooms**

Part of the BuyItDirect Group

## EU DECLARATION OF CONFORMITY

Company Name: Buy It Direct Buy It Direct  
Postal Address: Trident Business Park Leeds Road The Black Church St Mary's  
Postcode: HD21UA Place Dublin 7  
Telephone Number: 0330 390 3062 01 255 2070  
E-mail Address: Compliance@BuyItDirect.co.uk

This declaration of conformity is issued under our sole responsibility and belongs to the following product:

Type of Product: Intelligent Toilet  
Model Number: PURMBBTW  
Brand: Better Bathrooms  
Object of Declaration: PURMBBTW Intelligent Toilet

The object of the declaration described above is in conformity with the relevant Union harmonisation legislation:

Radio equipment Directive 2014/53/EU RoHS 2011/65/EU

Relevant harmonised standards used or other technical specifications in relation to which conformity is declared:

RED	EN 60335-1:2012+A15	EN 62233:2008
	EN 60335-2-84:2021+A11	
	EN 55014-1:2021	EN 61000-3-2:2019+A1
	EN 55014-2:2021	EN 61000-3-3:2013+A2
	EN 301 489-1 V2.2.3:2019	EN 301 489-3 V2.1.1:2019
	EN 55032:2015	EN 300 440 V2.1.1:2017
RoHS	Inc Amendment 2015/863	

Authorised Signature



Richard Leach  
Compliance and Quality Manager

14<sup>th</sup> January 2026

## UK DECLARATION OF CONFORMITY

Company Name: Postal Buy It Direct  
Address: Trident Business Park, Leeds Road,  
Postcode HD21UA  
Telephone Number 0871 620 1057  
E-mail Address Compliance@BuyItDirect.co.uk

This declaration of conformity is issued under our sole responsibility and belongs to the following product:

Type of Product: Intelligent Toilet  
Model Number: PURMBBTW  
Brand: Better Bathrooms  
Object of Declaration: PURMBBTW Intelligent Toilet

The object of the declaration described above is in conformity with the relevant designated standards:  
The Restriction of the Use of Certain Hazardous Substances in Electrical and Electronic Equipment Regulations 2012  
The Radio Equipment Regulations 2017

Relevant harmonised standards used or other technical specifications in relation to which conformity is declared:

RED	EN 60335-1:2012+A15	EN 62233:2008
	EN 60335-2-84:2021+A11	
	EN 55014-1:2021	EN 61000-3-2:2019+A1
	EN 55014-2:2021	EN 61000-3-3:2013+A2
	EN 301 489-1 V2.2.3:2019	EN 301 489-3 V2.1.1:2019
	EN 55032:2015	EN 300 440 V2.1.1:2017
RoHS	Inc Amendment 2015/863	

Authorised Signature



Richard Leach  
Compliance and Quality Manager

14<sup>th</sup> January 2026

# DECLARATION OF PERFORMANCE

## DOP BB-34FM

**Company Name:** Buy It Direct  
**Postal Address:** Trident Business Park, Leeds Road  
**Postcode** HD2 1UA

### CE

**Company Name:** Buy It Direct  
**Postal Address:** The Black Church, St Mary's Place,  
**Postcode:** Dublin 7  
**E-mail Address** Compliance@BuyItDirect.co.uk

This declaration of performance is issued under our sole responsibility and belongs to the following product:

**Type of product:** Floor Mounted Intelligent toilet and Back to Wall Intelligent toilet  
**Model Number:** BeBa\_24912 / BeBa\_26881/PURBBTW/ PURMBBTW  
**Brand:** Better Bathrooms  
**Object of Declaration** BeBa\_24912 and BeBa\_26881 and PURBBTW Floor Mounted Intelligent Toilets and PURMBBTW Intelligent Toilet

We hereby declare that the products named above have been designed, are produced and have been tested to comply with:

Union Harmonisation Legislation and relevant harmonised standards Regulation (EU) 2024/3110

Designated standards and relevant UK Statutory Instruments and Regulation Construction Products (Amendment) Regulations 2022 - SI 2022/712

BS EN997:2012+A1:2015

Personal Hygiene

AVCP System 4

Essential Characteristics

CL 1 -6A – Class 1 product/ Flushing cistern PASS

WL – Water Tightness / Leak Tightness PASS

BP – Back Flow Prevention PASS

CA - Cleanability PASS

LR – Load Resistance PASS

DA – Durability PASS

Authorised Signature



Craig Watson

Technical Manager

20<sup>th</sup> January 2026